

VALVE ASSEMBLY DETAIL
SCALE: NONE

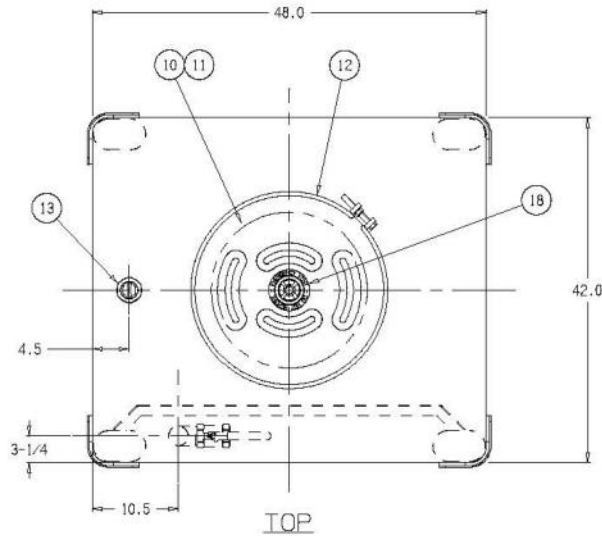

TOP

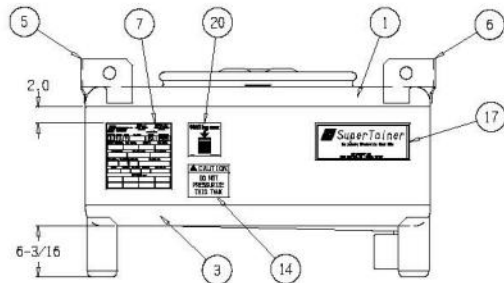

LEFT SIDE

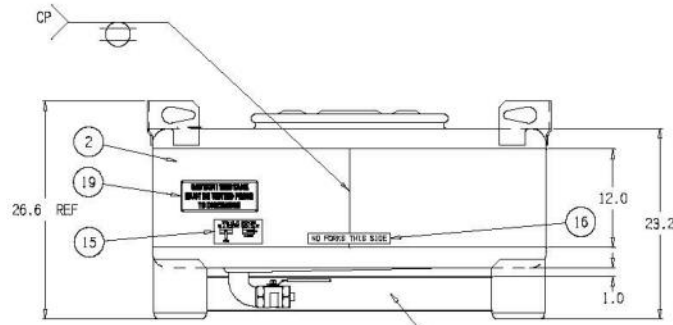

FRONT

REVISION				
NO.	DATE	DESCRIPTION	BY	APPD.
a	04/10/2008	CHANGE PART 3	WRB	
b	05/25/2010	FITTING DIMENSION LOCATION CHANGED FROM 6" TO 4-1/2"	JCB	LT
c	06/30/2010	ADDED CAUTION DECAL	JCB	LT
d	11/18/2010	ADDED IBC STACKING DECAL	JCB	
e	11/19/2012	UPDATE TO CURRENT PRODUCTION STANDARDS	CEB	JCB

NOTES:

- TANK IS DESIGNED AND CONSTRUCTED IN ACCORDANCE WITH U.N. SPECIFICATIONS
- TANK IS AIR TESTED AT 3 PSI
- ALL WELDS CLEANED OF SLAG AND SPATTER
- TANK INTERIOR AND EXTERIOR ARE ELECTRO-CLEANED
- DRUM LID TO BE INSTALLED BY: STRIKE RING AROUND CIRCUMFERENCE WITH A Mallet THEN TIGHTEN THE BOLT WITH A WRENCH. REPEAT UNTIL BOLT TIGHTENING RESISTANCE DOES NOT CHANGE (REF: 40 LB-FT)
- 2IN BUNG TO BE INSTALLED 3/8 TO 1/2 ROTATION BEYOND SOLID GASKET CONTACT (REF: 30 LB-FT)

NO.	QTY.	PART NUMBER	DESCRIPTION
20	1	99700352	IBC STACKING DECAL - [126 SUPERTAINER]
19	1	99700315	DECAL CAUTION VENT PRIOR TO DISCHARGE
18	1	99700246	DECAL EMERGENCY VENT
17	1	99700260	DECAL SUPERTAINER
16	1	99700247	DECAL NO FORKS THIS SIDE
15	1	99700248	DECAL REVERSE STEM VALVE OPEN/CLOSE
14	1	99700258	DECAL DO NOT PRESSURIZE
13	1	35901511	PLUG 2IN HEX HEAD WH EPDM GASKET 304SS
12	1	34701360	ASM BOLTED CLAMP RING 22-5/16 ZINC-PLTD
11	1	35901163	LID 22-5/16 DOT 10GA W/RIEKE 304SS
10	1	33100387	GASKET 22-5/16 DIA MULTIPURPOSE EPDM
9	1	34200833	PLUG PVC 2IN NPT SQ HD
8	1	35400242	VALVE 2IN REV-STEM BV LOCK-HNDL 316SS S.I.
7	1	36500069	PLATE UN SUPERTAINER 304SS DWG#B4462
6	2	35901455	LIFTING LUG L 304SS
5	2	35901454	LIFTING LUG R 304SS
4	1	35901173	VALVE GUARD 4-1/4 X 43-1/2 X 10GA 304SS
3	1	35902034	ASM BTM 42 X 48 X 10GA W/LEGS & SWEEP EL 304SS
2	2	33800338	SHEET 12 X 87-7/8 X 10GA 1SIDE PVC 304SS
1	1	35902036	ASM TOP 42 X 48 X 10GA W/2IN WP 304SS

BILL OF MATERIALS

CUSTOMER:	
JOB:	
SCALE: NONE	DRAWN BY: JCB
DATE: 10/07/2008	CHECKED BY: LT
DESCRIPTION: 126 GAL 42 X 48 SUPERTAINER SS	DRAWING NUMBER: 21396e