

© DEN HARTOG INDUSTRIES, INC.

Copyright All information furnished within this document, electronic file or design correspondence is the property of Den Hartog Industries, Inc. and shall not be used, disclosed to others or copied without the expressed written consent of Den Hartog Industries, Inc.

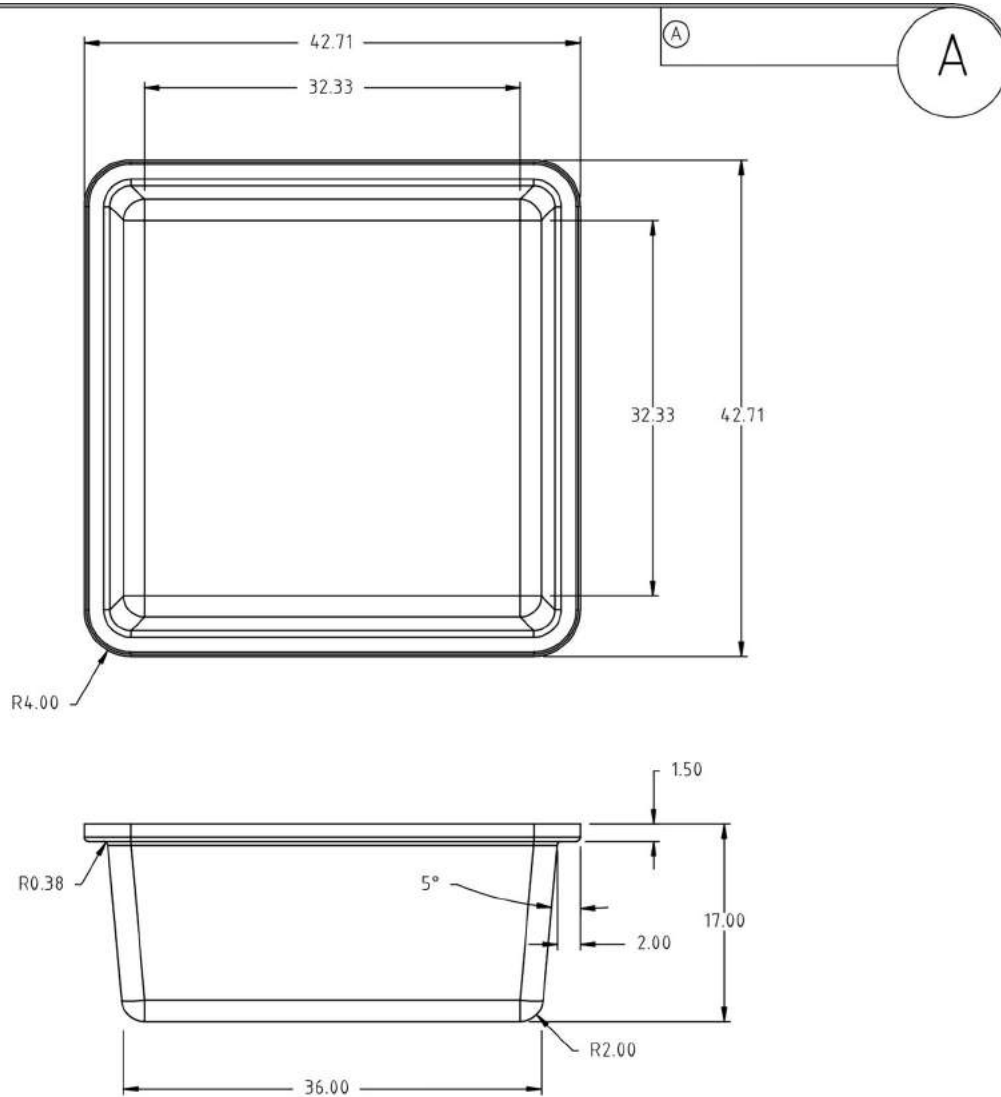
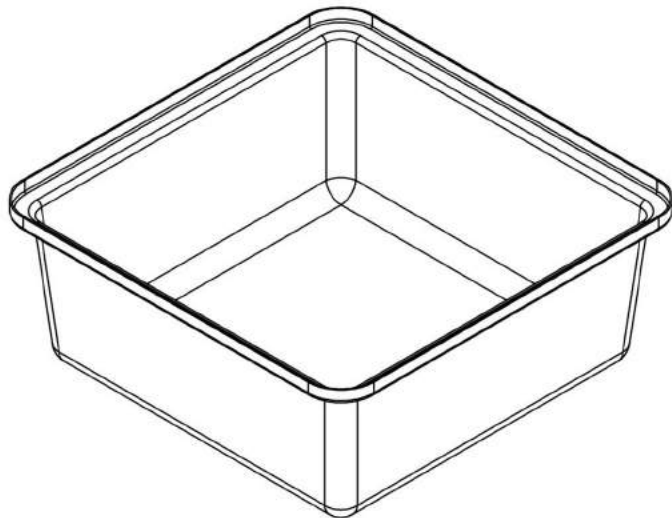

				DRAWN / DATE ADH 2/6/12	MATERIAL	
A	"OP" PART NUMBER WAS "OPR"	ADH 3/27/14	2830	APPRD. / DATE REH 2/6/12	10420 NATURAL	
REV	DESCRIPTION	BY / DATE	CCN			
ALL DIMENSIONS ARE IN DECIMAL INCHES TOLERANCES UNLESS OTHERWISE SPECIFIED		THIRD ANGLE PROJECTION ANSI 14.5M		SHOT WEIGHT: 53 LB.	NOTES: 1.) NOM. WALL 0.18"	DESCRIPTION 100 GALLON CONTAINMENT TANK
POLYETHYLENE	METAL DECIMAL ± .125" FRACTION ± 1/4" ANGLE ± 1°			SHIPPING WEIGHT: 26 LB.		SCALE N.S.
±1% @ 68°F				FINISH:		

OCA100-RT

(866) 776-8265

PROTANK

sales@protank.com