

Copyright. All information furnished within this document, electronic file or design correspondence is the property of Den Hartog Industries, Inc. and shall not be used, disclosed to others or copied without the expressed written consent of Den Hartog Industries, Inc.

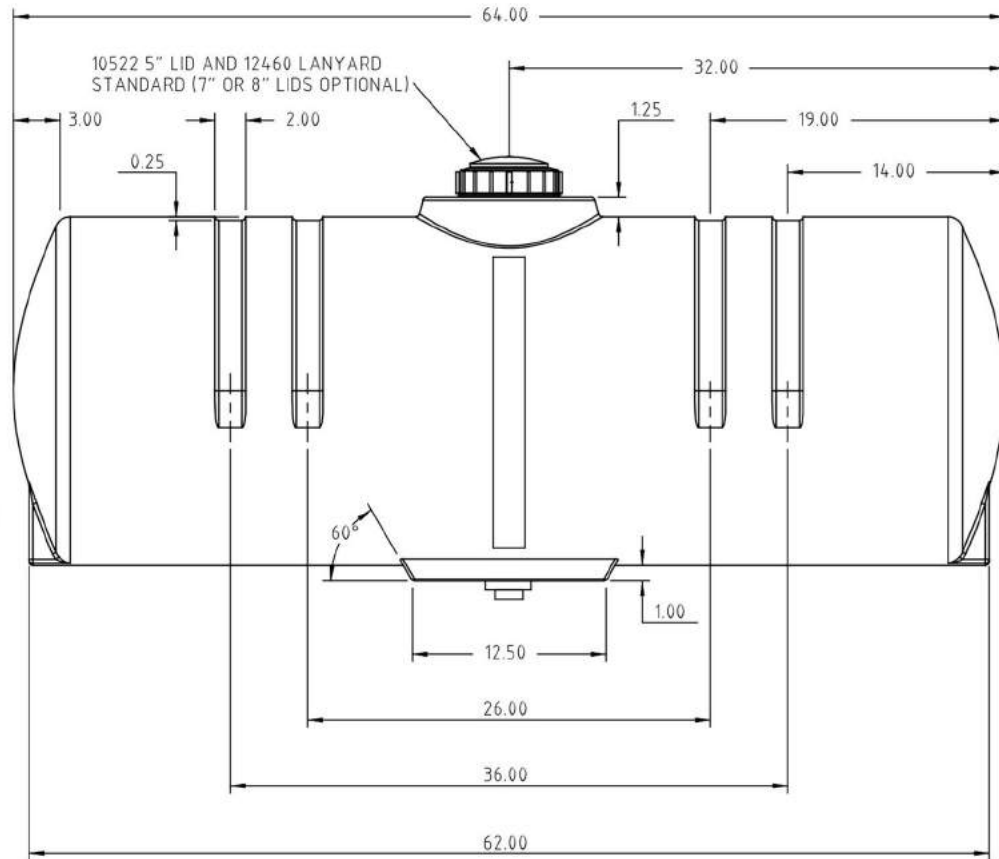
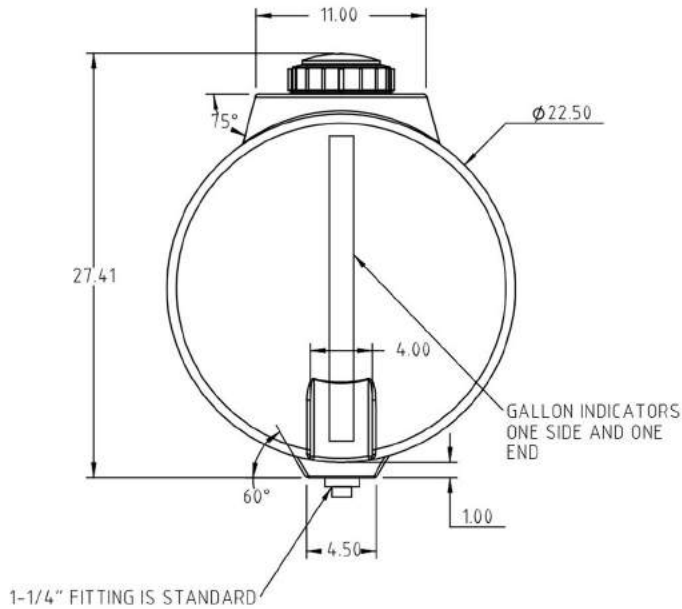

				DRAWN / DATE ADH 6/29/09	MATERIAL 10420 3 MELT		
				APPRD. / DATE REH 6/29/09			
REV	DESCRIPTION	BY / DATE	CCN	SHOT WEIGHT: 38 LB.		DESCRIPTION 100 GALLON HORIZONTAL TANK	
ALL DIMENSIONS ARE IN DECIMAL INCHES TOLERANCES UNLESS OTHERWISE SPECIFIED		THIRD ANGLE PROJECTION ANSI 14.5M		SHIPPING WEIGHT: 40 LB.		SCALE N.S.	
POLYETHYLENE		METAL DECIMAL ± .125" FRACTION ± 1/4" ANGLE ± 1°		FINISH:		PART NO.	
±1% @ 68°F							