

Copyright. All information furnished within this document, electronic file or design correspondence is the property of Den Hartog industries, Inc. and shall not be used, disclosed to others, or copied without the expressed written consent of Den Hartog Industries, Inc.

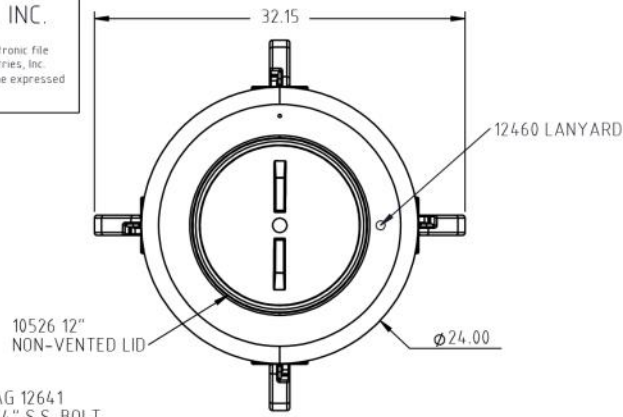

HARDWARE BAG 12641  
 (1) 5/16" X 1 1/4" S.S. BOLT,  
 (1) L. NUT & (2) S.S. WASHERS  
 20 PLACES

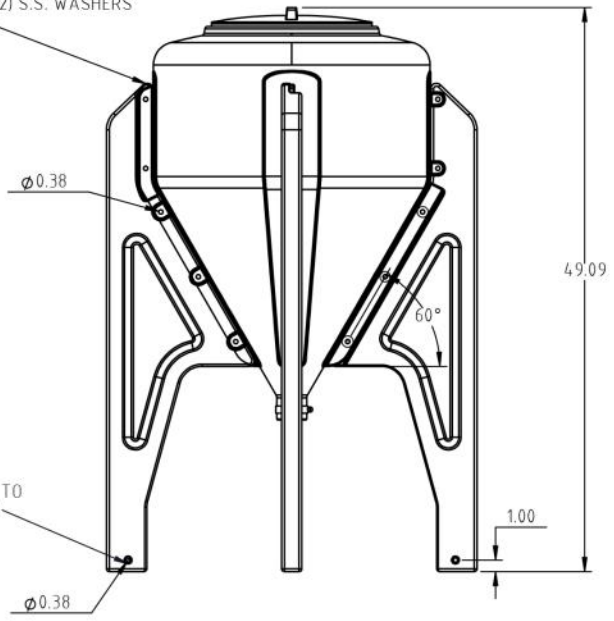

USE THESE HOLES TO  
 ANCHOR INDUCTOR

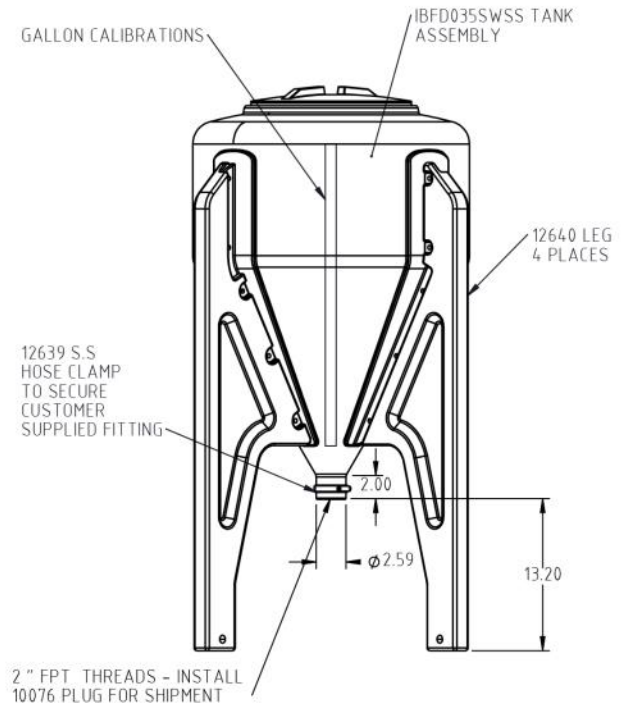

		DRAWN / DATE ADH 8/25/08		MATERIAL	
		APPROD. / DATE REH 6/11/09			
REV	DESCRIPTION	BY / DATE	CCN		
ALL DIMENSIONS ARE IN DECIMAL INCHES TOLERANCES UNLESS OTHERWISE SPECIFIED		THIRD ANGLE PROJECTION ANSI 14.5M		NOTES:	
POLYETHYLENE		METAL DECIMAL ± .125" FRACTION ± 1/4" ANGLE ± 1°		SHOT WEIGHT:	
±1% @ 68° F				SHIPPING WEIGHT:	
				FINISH:	
DESCRIPTION 35 GALLON BLOW MOLDED INDUCTOR AND LEGS					
SCALE N.S.		PART NO.			