

© DEN HARTOG INDUSTRIES, INC.

Copyright. All information furnished within this document, electronic file or design correspondence is the property of Den Hartog Industries, Inc. and shall not be used, disclosed to others or copied without the expressed written consent of Den Hartog Industries, Inc.

STANDARD TANK ASSEMBLY

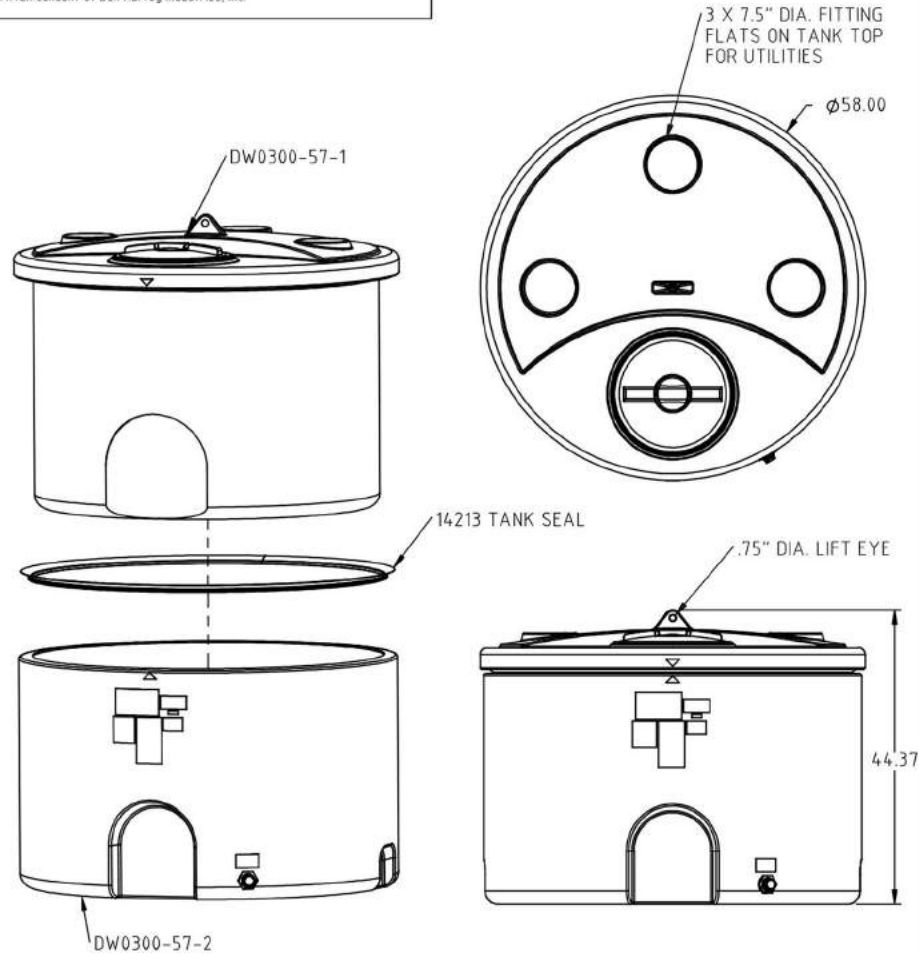

TANK ASSEMBLY WITH OPTIONAL 2" FITTING

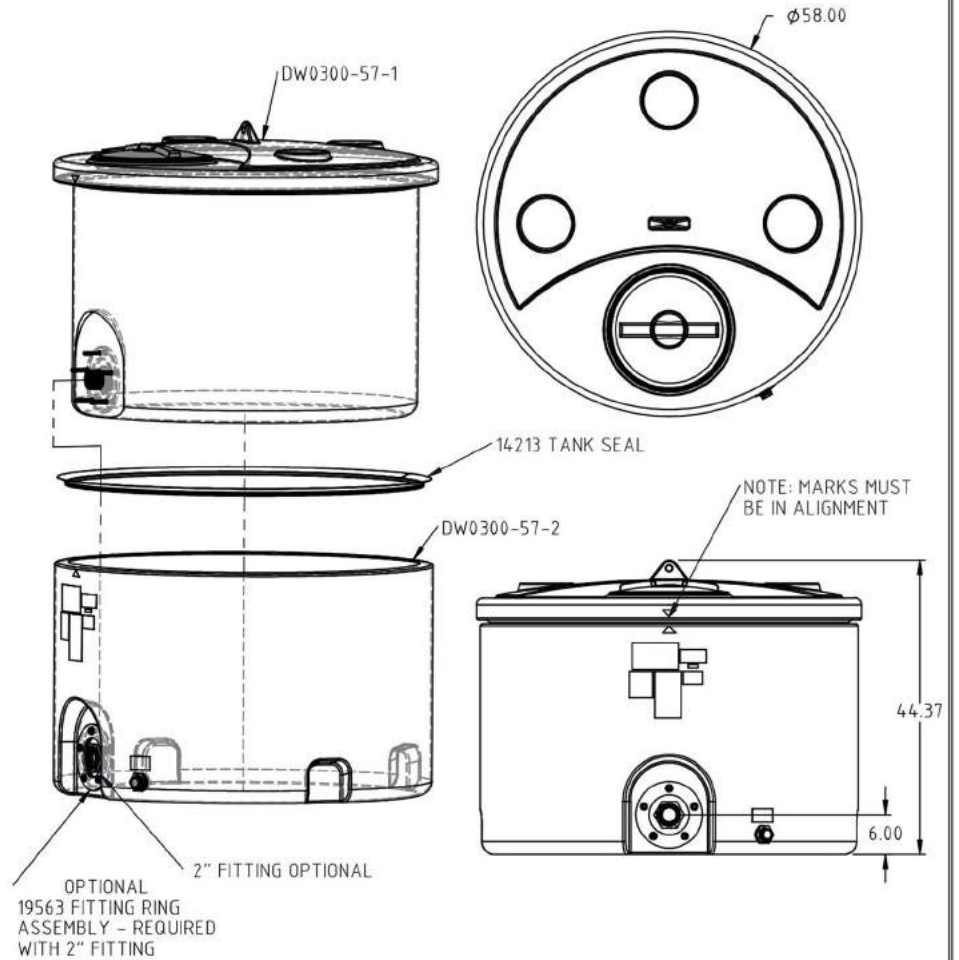

		DRAWN / DATE ADH 8/7/14		MATERIAL SEE NOTE 1	
		APPRD. / DATE REH 8/12/14			
REV	DESCRIPTION	BY / DATE	CCN		
ALL DIMENSIONS ARE IN DECIMAL INCHES TOLERANCES UNLESS OTHERWISE SPECIFIED		THIRD ANGLE PROJECTION ANSI 14.5M		NOTES: 1.) REFERENCE COMPONENT PRINTS FOR DETAILS 2.) PATENT PENDING	
POLYETHYLENE ±1% @ 68° F		METAL DECIMAL ± .125" FRACTION ± 1/4" ANGLE ± 1°		DESCRIPTION 300 GALLON DUAL LINE™ TANK ASSEMBLY	
		SHOT WEIGHT: SHIPPING WEIGHT: STANDARD = 190 LBS. FINISH:		SCALE N.S.	
				PART NO.	

DWA300

(866) 776-8265

PROTANK

sales@protank.com