

Copyright. All information furnished within this document, electronic file or design correspondence is the property of Den Hartog Industries, Inc. and shall not be used, disclosed to others or copied without the expressed written consent of Den Hartog Industries, Inc.

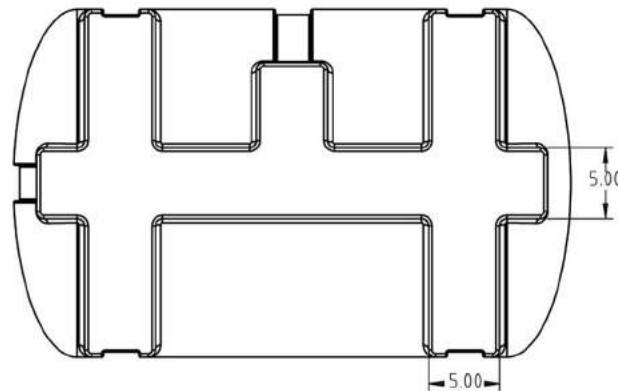
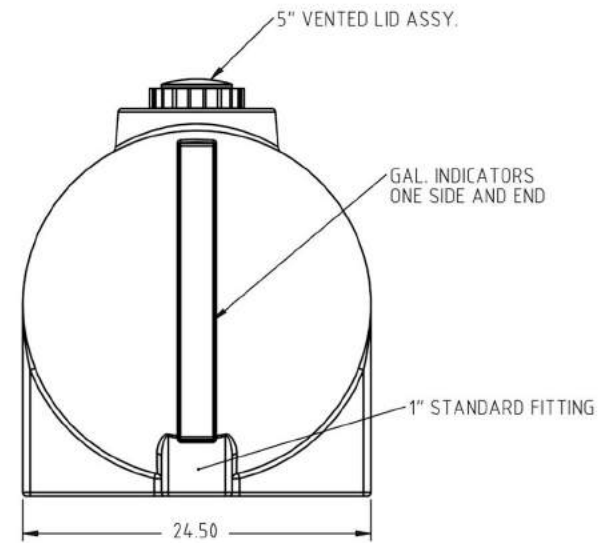
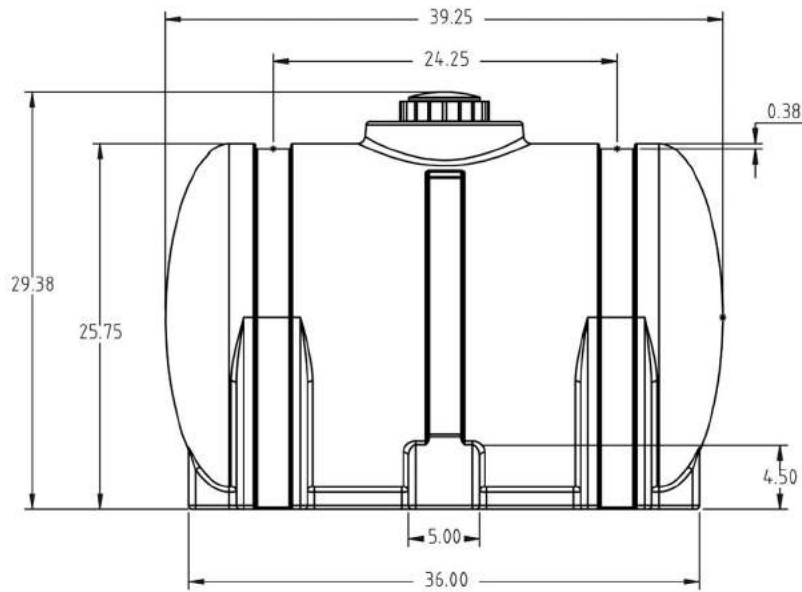

				DRAWN / DATE DHJ 5/30/02	MATERIAL B	
B	DRAWING TEMPLATE UPDATED, MATERIAL/SHIPPING WEIGHT ADDED	ADH 7/26/10	2065		1.) POWDER, 3 MELT	
A	CHANGE WEIGHT	8/12/05		APPRD. / DATE REH 5/30/02		
REV	DESCRIPTION	BY / DATE	CCN			
ALL DIMENSIONS ARE IN DECIMAL INCHES TOLERANCES UNLESS OTHERWISE SPECIFIED		THIRD ANGLE PROJECTION ANSI 14.5M		SHOT WEIGHT: 32.00 LBS	NOTES: 1.) WHITE, YELLOW, OR BLACK COLOR 2.) NOM. WALL .200	DESCRIPTION 65 GALLON FREE STANDING TANK
POLYETHYLENE ±1% @ 68° F		METAL DECIMAL ± .125" FRACTION ± 1/4" ANGLE ± 1°		SHIPPING WEIGHT: 33.00 LBS		SCALE N.S.