

ISOMETRIC VIEW

U.N. MARKING ON TANK READS:

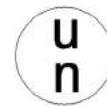

31H1 / Y / MO. / YR. / USA  
 SNYDER IND. INC.  
 LINCOLN, NE. 4540 / 1713  
 CAPACITY - 833 LITERS  
 TARE MASS - ACTUAL KG  
 GAUGE TEST PRESSURE - 100 KPA  
 LAST LEAKPROOFNESS TEST - MO. / YR.  
 LAST INSPECTION - MO. / YR.

**220 STANDARD ULTRATAINER "STANDARD PACKAGE OF OPTIONAL EQUIPMENT"**

ITEM #	DESCRIPTION	QTY.	PART NUMBER
1	TANK - NO BUNG TANK WITH 20" CAP AND 6" HEAVY DUTY CAP IN CENTER AND BOTTOM DRAIN HDPE NATURAL.	1	
2	BASE - BASE 220 STANDARD ULTRATAINER HD/BLUE	1	
3	TOP PROTECTOR ULTRA HD/BLUE	1	
4	PIN ASSEMBLY PURCHASED PLASTIC W/BOLTS FOR ULTRA.	1	
5	S.I.I. PROPRIETARY 2" NPS REPLACEABLE BUNG GLASS FILLED POLYETHYLENE W/VITON O-RING SEAL	2	
6	2" NPS RIEKE POLYETHYLENE BUNG PLUGS WITH EPDM FLAT GASKETS	2	
7	20" GREY ROTOMOLDED CAP WITH 6" HEAVY DUTY CAP IN THE CENTER AND WITH A 2" NPS CENTER OPENING IN THE 6" CAP COMPLETE WITH AN EPDM CAP GASKET.	1	
8	S.I.I. 2" NPS VACUUM RELIEF VENT WITH EPDM DISK AND FLAT GASKET (AVERAGE GRAVITY FLOW RATE OF 70 GALLONS PER MINUTE)	1	
9	2" BANJO STANDARD PORT GLASS FILLED POLYPROPYLENE BOTTOM DRAIN VALVE WITH TEFLON SEATS AND BALL AND 18/8 S.S. BOLTS. INCLUDES DUST CAP AND CAP LANYARD.	1	

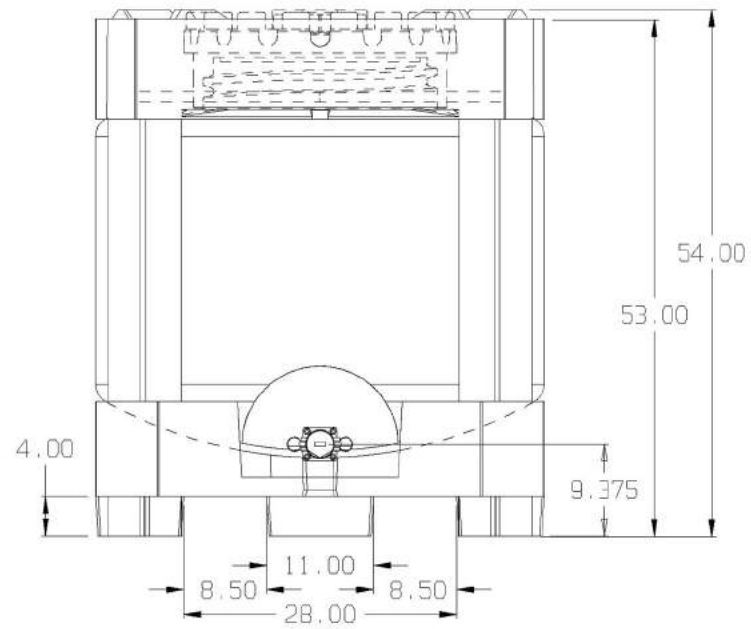

(all dimensions in inches)  
 (all dimensions nominal)

PART # TANK:

220 GALLON STANDARD ULTRATAINER W/20" CAP

REF#: 0000

08/19/02