

MANUFACTURER	AQUAMATE
MODEL	UR4D205
GROSS CAPACITY	16,200 GALLONS
NET CAPACITY	14,670 GALLONS
SHELL COLOR / FINISH	NO COLOR / GALVANIZED FINISH
SHELL MOISTURE BARRIER	20mil UNSUPPORTED PE
LINER	ENVIROLINER 20mil
ROOF SHEETING	CORRUGATED 2.67" PITCH 7/8" DEPTH

ID	ACCESSORIES
A1	30" HINGED ROOF ACCESS HATCH
A2	LIGHT DUTY LADDER - 3 RING TANK
A3	205" GEOMAT
A4	DUST AND VERMIN PROTECTION
A5	6" PVC OVERFLOW PIPEWORK
A6	MECHANICAL LEVEL GAUGE

NOTES

GENERAL

- DRAWINGS TO BE READ IN CONJUNCTION WITH DESIGN SPECIFICATION
- EFFECTIVE VOLUME CALCULATION BASED ON STORAGE LOSS BELOW INVERT OF THE LOWEST OUTLET AND FROM 1" BELOW THE INVERT / LIP OF THE LOWEST OVERFLOW

PRODUCTION

- ALL PIPEWORK & VALVES, UNLESS SPECIFIED, BY OTHERS

INSTALLATION

- ENSURE FIRM FLAT AND LEVEL SITE IS PROVIDED, AS PER SITE PREPARATION SPECIFICATION, PRIOR TO COMMENCING CONSTRUCTION
- ORIENTATION OF ALL FITTINGS TO BE CONFIRMED PRIOR TO INSTALLATION
- INSTALLATION TOLERANCES APPLY IN ADDITION TO STANDARD PRODUCTION TOLERANCES

114.0	16,200
112.5	16,000
109.5	15,600
106.5	15,200
103.5	14,700
100.5	14,300
97.5	13,900
94.5	13,500
91.5	13,000
88.5	12,600
85.5	12,200
82.5	11,800
79.5	11,300
76.5	10,900
73.5	10,500
70.5	10,000
67.5	9,600
64.5	9,200
61.5	8,800
58.5	8,300
55.5	7,900
52.5	7,500
49.5	7,100
46.5	6,600
43.5	6,200
40.5	5,800
37.5	5,300
34.5	4,900
31.5	4,500
28.5	4,100
25.5	3,600
22.5	3,200
19.5	2,800
16.5	2,400
13.5	1,900
10.5	1,500
7.5	1,100
4.5	600
1.5	200
INCHES	US GAL
Ø205" TANK	
DEPTH CHART	

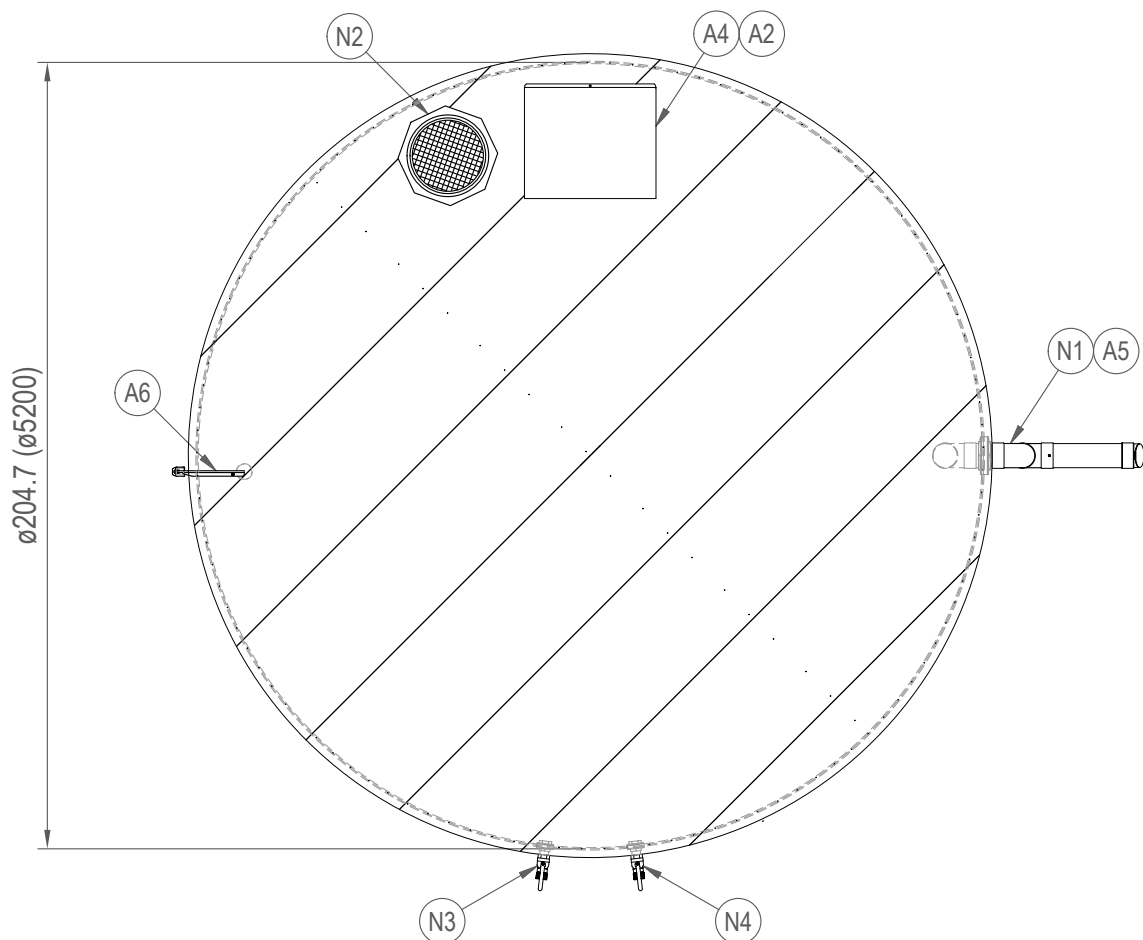

TANK PLAN
SCALE: 1:50

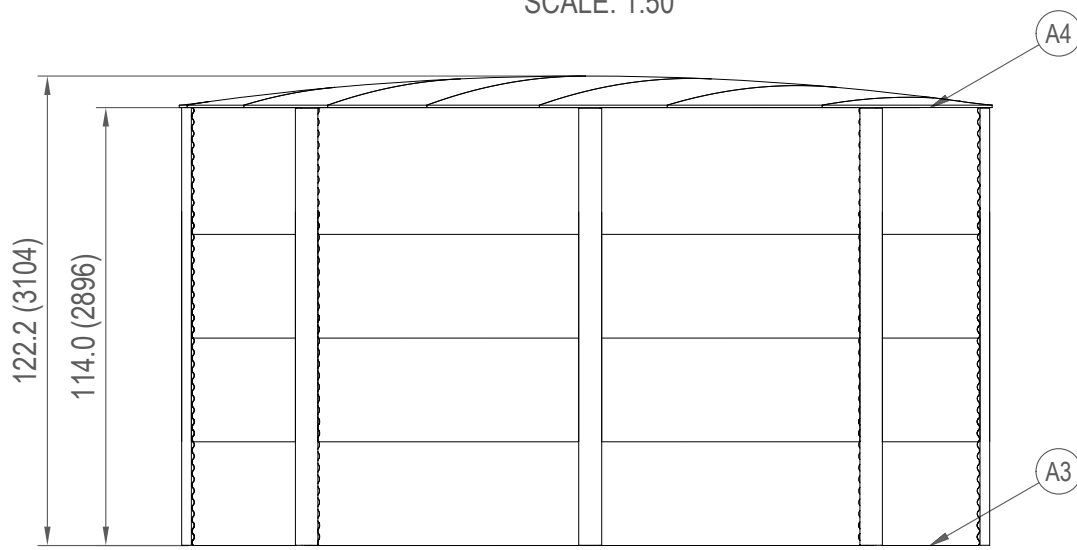

TANK ELEVATION
SCALE: 1:50

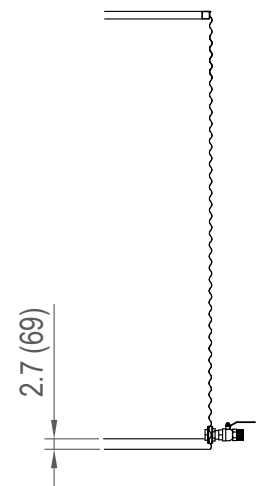

DRAIN
SCALE: 1:50

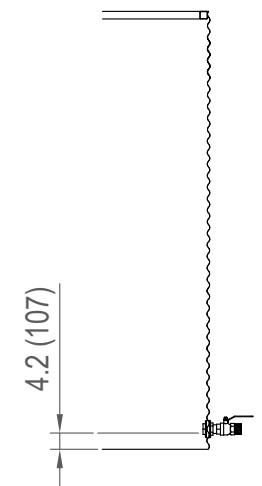

OUTLET
SCALE: 1:50

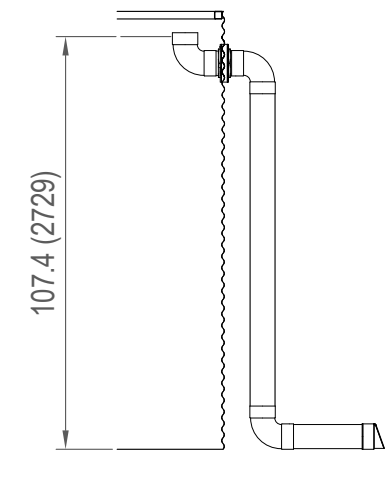

OVERFLOW
SCALE: 1:50

ID	DESCRIPTION	SIZE	TYPE	LVL.	MATERIAL	VALVE TYPE	INTERNAL
N1	OVERFLOW	6"	SDR 35	82.5	ASA	-	VERTICAL ORIFICE
N2	INLET	20"	BASKET	114.0	PP / PE	-	UV GUARD
N3	OUTLET	2"	Sch 40	5.25	GFN	Ni COATED BALL	HORIZONTAL ORIFICE
N4	DRAIN	2"	Sch 40	3.75	GFN	Ni COATED BALL	HORIZONTAL ORIFICE

AQUAMATE
 aquamatetanks.com
 4906 Dillehay Drive
 Ste 200, Allen TX 75002
 844.320.8265
 info@aquamatetanks.com

INIT.	DATE	DESCRIPTION

16,000 GALLON TANK GENERAL ARRANGEMENT
 AQUAMATE TANKS
 PRODUCTION PART

REV.	DESCRIPTION	DATE	DRAWN	APPROVED
-1	FIRST ISSUE	24 NOV 16	BAF	---

INCHES (MILLIMETRES)	SCALE REFER SHEET	SHEET 1 of 1	Weight	PROJ. No. D030	DWG. No. U-05.2-1000-00003	REV.	SHEET SIZE B ANSI
----------------------	-------------------	--------------	--------	----------------	----------------------------	------	-------------------